

NOTE

1. MIN HEADER SIZE 1-3/4" X 4".
2. CUT OUT FOR COVER PLATE 3-3/4" X 15-3/4".
3. DO NOT SCALE DRAWING.
4. DIMENSIONS ARE IN INCHES/(MM).
5. CLEARANCE BETWEEN HEADER AND DOOR 1/8".
6. PIVOT 8570 CAN BE SHORTENED FOR 1-9/16" WEB DEPTH.
7. AUXILIARY STOP REQUIRED COINCIDING WITH DEADSTOP ON RTS CLOSER.

FOR 8-32 MACHINE SCREWS USE No.29 (0.136") DRILL DRILL AND TAP THREE (3) HOLES

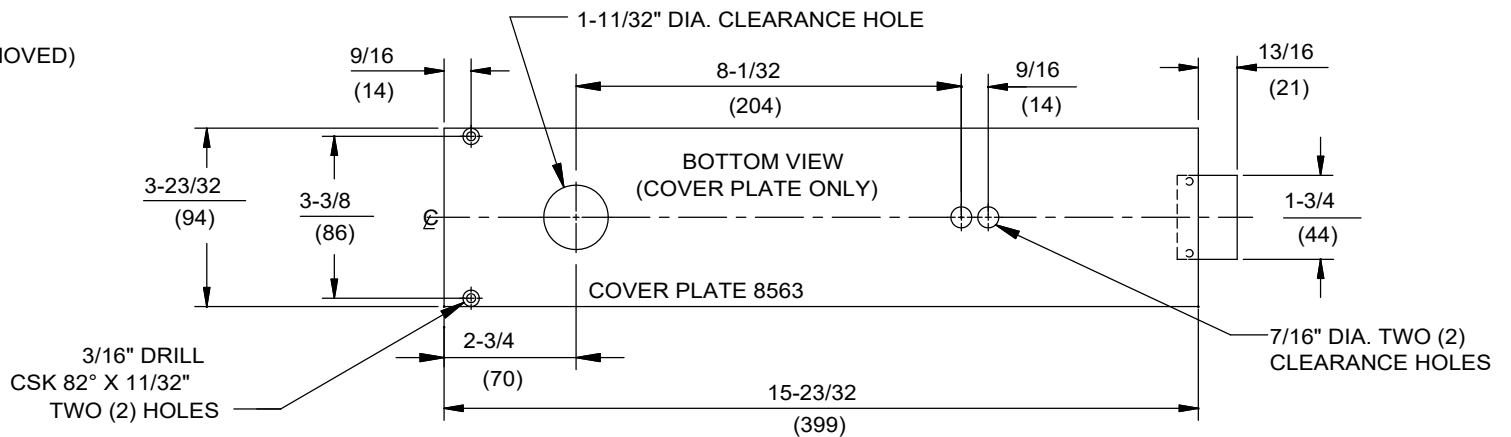
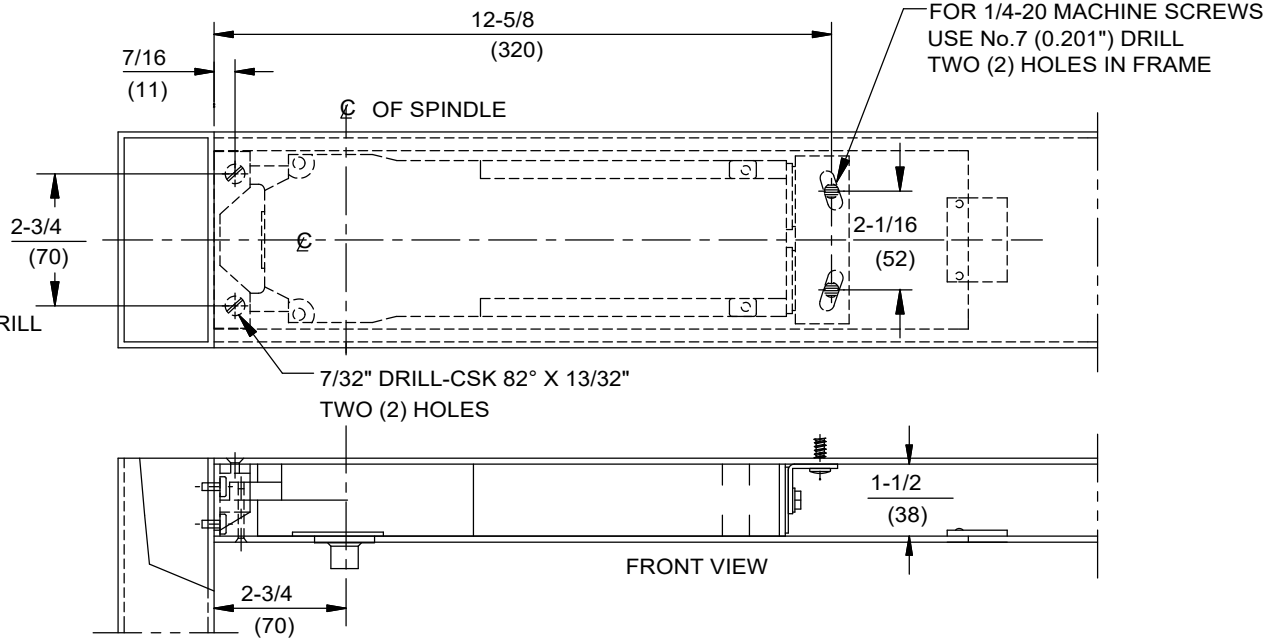
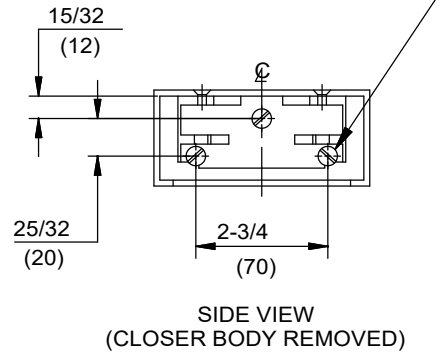

DOOR CLOSER MODEL: RTS SERIES SIDE LOAD PACKAGE 01 AND 02  
 ALUMINUM DOOR AND FRAME, CENTER PIVOTED 2-3/4" BACKSET  
 No. 8831 SIDE LOAD ARM, No. 8570, 8572 PIVOTS  
 No. 8563 COVER PLATE - WITH SLOTTED ANGLE BRACKET

